Activity: **Building Tetrahedral Kites**

GRADE LEVELS: 6-8

SUMMARY:

Working in teams of four, you and your team will build a tetrahedral kite following a specific set of directions and using specific provided materials. You will use basic processes of manufacturing systems – cutting, shaping, forming, conditioning, assembling, joining, finishing, and quality control – to manufacture a complete tetrahedral kite within a given time frame. Evaluation of your project will involve the efficiency of your team as well as your finished product.

LEVEL OF DIFFICULTY [1 = Least Difficult: 5 = Most Difficult]

3 -average

TIME REQUIRED

45-90 minutes (1-2 class periods, depending on depth of concept discussion)

COST

\$10-\$20 (Approx. \$5 per kite constructed)

STANDARDS:

- 4.1 Describe and explain the manufacturing systems of custom and mass production.
- 4.4 Explain basic processes in manufacturing systems, e.g. cutting, shaping, assembling, joining, finishing, quality control, and safety.
- 6.4 Identify and explain lift, drag, friction, thrust, and gravity in a vehicle or device, e.g., cars, boats, airplanes, rockets.

WHAT WILL THE STUDENTS LEARN?

Basic elements of flight

Basic manufacturing systems and processes

BACKGROUND INFORMATION:

VOCABULARY:

DRAG: A frictional force acting on a body (as an airplane) moving through a fluid (as air) parallel and opposite to the direction of motion.

LIFT: the component of the total aerodynamic force acting on an airplane or airfoil that is perpendicular to the relative wind and that for an airplane constitutes the upward force that opposes the pull of gravity.

GRAVITY: A force of attraction between two objects due to the mass of the objects and the distance separating them.

TENSION: Two pulling forces directly opposing each other that stretches an object. Tension in the string keeps a kite from flying away.

RELATIVE WIND: The relative wind, therefore, is the airflow produced by the aircraft moving through the air. The relative wind is in a direction parallel with and opposite to the direction of flight.*

NEWTON'S 3rd LAW OF ACTION AND REACTION: states that for every action there is an equal and opposite reaction.

BERNOULLI'S THEOREM: states that as air passes below a wing, air also passes above it. The air on the top of the wing moves a longer distance over the curved surface of the wing, thus it moves faster reducing the pressure above the wing. The air below the wing moves more slowly causing the air pressure below the wing to be larger than the pressure above the wing. It is the change in relative pressures above and below the kite that allows the kite to lift.

Kites were the first flying devices ever made by humans. The word “kite” gets its name from a bird in the hawk family known for its grace in the air. Kites come in a wide variety of shapes and sizes and have been used for many purposes throughout history, although today, kite flying is done largely for recreation.

See figure 1 for a full picture of a tetrahedral kite.

RECOMMENDED RESOURCES:

Websites/Books dealing with kites (types, construction, history, etc.), flight

<http://qldkiteflyerssociety.com.au/linkfarm.html> - links to specific kite types

<http://easyweb.easynet.co.uk/~s.stapleton/kites/build.html> -Materials, etc.

<http://www.win.tue.nl/~pp/kites/fak/> - FAQs

<http://www.win.tue.nl/~pp/kites/ifosk/build.html> -look at links

<http://www.asahi-net.or.jp/~et3m-tkkw/history-table.html> - kite history

<http://www.geocities.com/Colosseum/4569/history.htm> - kite history

<http://www.zianet.com/katgraham/kites/eddylesson.html> - kite construction

<http://www.intellicast.com/KITEcast/Windandkites/> - Fly a virtual kite

<http://www.scratch-pad.com/kites/fly.html> - Go and Fly a Kite Website,

information on how a kite flies

http://muttley.ucdavis.edu/Curriculums/Vehicles/kite_summary.html - how kites

fly

MATERIALS:

Kite string

Glue sticks

4 full size sheets of Tissue paper per kite

7 3/4 " tall plastic straws (not the flexible kind), 60 per kite

Pipe cleaners (1 per kite)

Scissors

Poster board or oak tag (1/4 board per kite)

Pencils

PREPARATION:

Obtain Materials

Photocopy Worksheets

DIRECTIONS:

www.prek-12engineering.org

Copyright © 2001

All Rights Reserved

PHASE ONE – Making Pyramids (see Diagram)

1. Obtain six straws, measure and cut a 72” long piece of kite string. Thread 4 straws on the kite string. Hold on to the ends. Keep approximately 3 inches of string towards end A.
2. Arrange the straws onto a diamond shape and use the pipe cleaner “needle” to feed the string through the starter straw, so that it comes out between straw 1 and straw 2.
3. Add the fifth straw and place it across the center of the diamond.
4. Feed the “needle” back through the third straw so that it comes out between straw 2 and 3.
5. Add the sixth straw. Pull up the straws so that a triangle is formed. Tie it off so that your triangles form a stable pyramid shape.

Now, using steps 1-5 make 9 more pyramids!

PHASE TWO – Building the Kite {pictures of each step can be seen at <http://ford.berea.k12.oh.us/Kitewebpage/Tetra.htm> (Ref. 1)}

6. Using the template, carefully trace and cut out 20 tissue paper shapes.
7. Cover two sides of each pyramid with tissue paper. Fold the edges of the tissue paper around the straw and glue in place.
8. Assemble the kite. Begin with the bottom layer. Arrange three pyramids side by side so that they only touch by one corner and the front of each is a covered panel (all of the covered panels should lie in a plane). The other covered panel should be lying flat on the table. Knot the pyramids at the points where they meet. Arrange two pyramids behind those three so that the front covered panels of the two new pyramids faces the same direction as the front three. The back corners of the front three just meet the front corners of the two behind. Knot the two pyramids at all points that touch. Attach one more pyramid to the back corners of the row with two, again facing the covered panel forward. Be sure that all knots are secure!
9. Add the second layer of pyramids. Arrange two pyramids side by side (make sure the covered panels are on the bottom and front). Knot them to each other. Align the bottom corners of these two with the peaks of the front five pyramids on

the bottom layer. Knot these two pyramids to the bottom layer. Arrange and attach a third triangle behind the two you just attached. Be sure that all knots are secure!

10. Add the third and final layer. Attach a single pyramid on top of the second level still having the covered panel facing forward. The finished kite itself looks like a giant pyramid. Be sure that all knots are secure!

11. Attach kite strings to the corners where the front panel meets the back panel. With the strings here, the panels will face downward when in flight and the triangles will look like birds in flight.

12. Add a tail to keep the kite properly oriented towards the wind.

PHASE THREE – Flying your Kite

13. Check the knotting. Attach flying string. Go out and fly your kite!

INVESTIGATING QUESTIONS:

How and why do objects move upward?

Why do kites fly?

How can a team of students most efficiently produce a finished product – the tetrahedral kite – using manufacturing processes?

How will modifications of the project's initial design alter the kite's performance?

REFERENCES:

<http://ford.berea.k12.oh.us/Kitewebpage/Tetra.htm>

SAMPLE RUBRIC:

4 (Advanced) Project exceeds guidelines set by teacher

3 (Proficient) Project meets guidelines

2 (Developing) Project meets some guidelines

1 (Beginning) Project fails to meet guidelines or is incomplete

0 Project not attempted

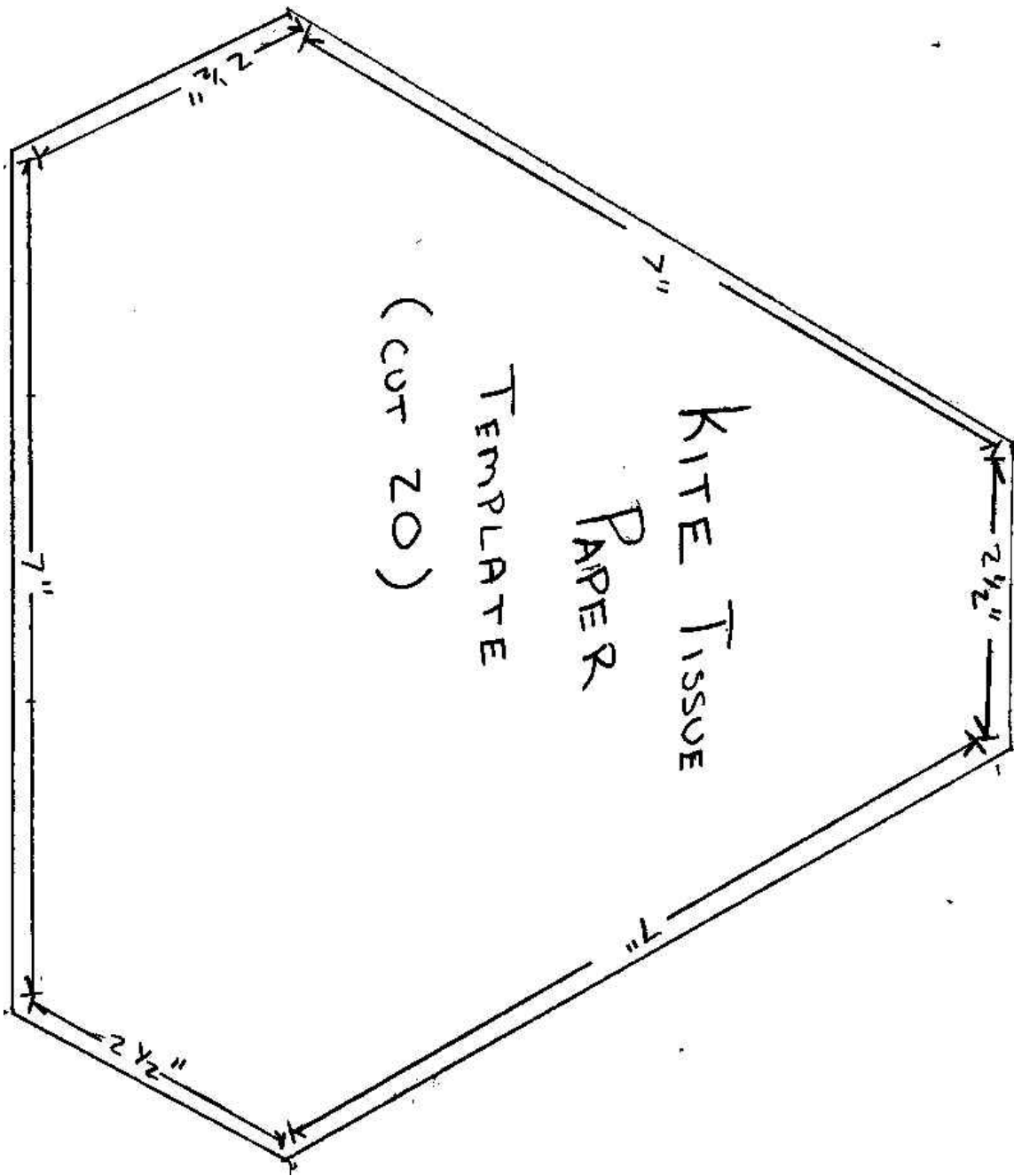

STEP 1.



STEP 2.

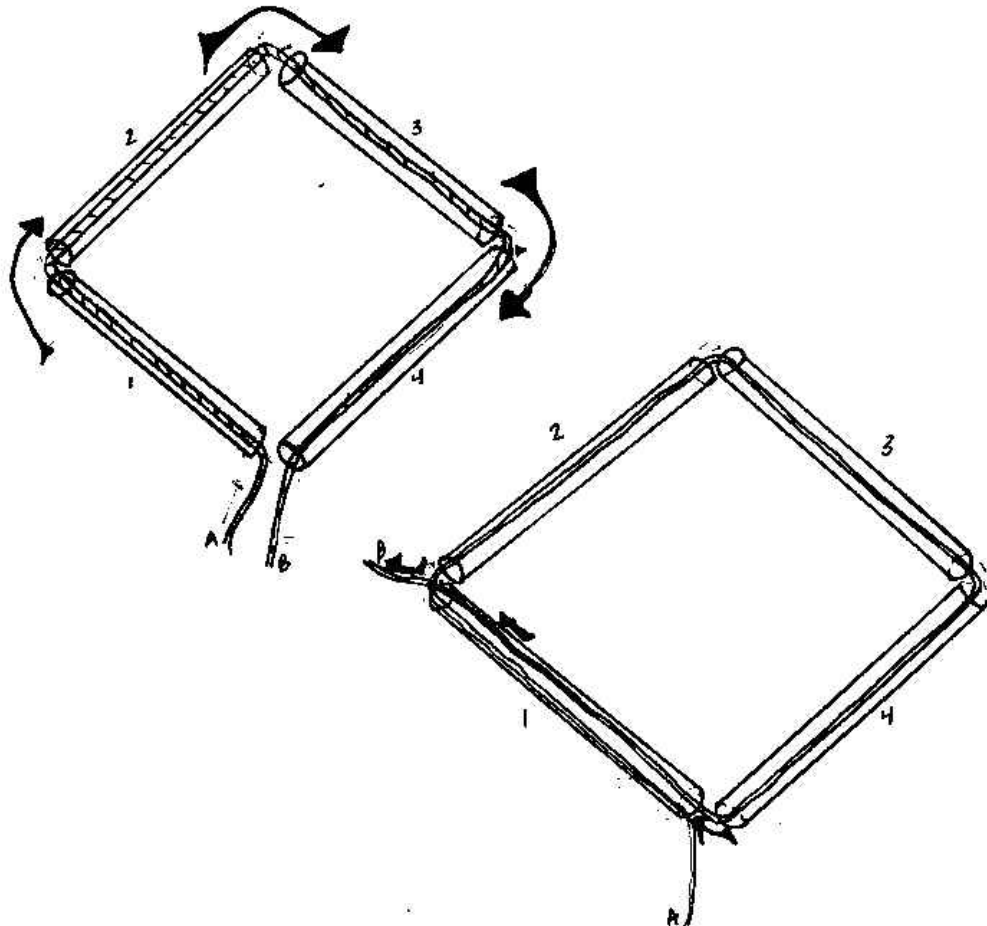

STEP 3.

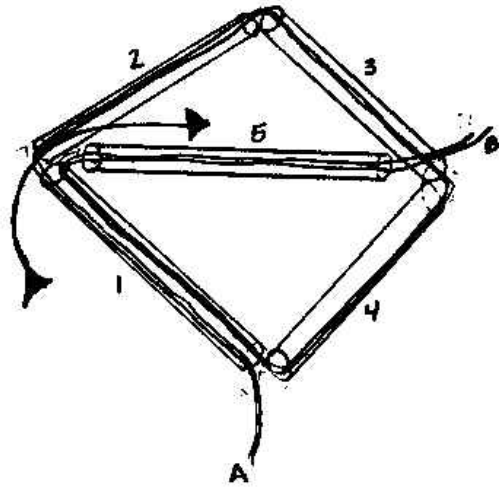
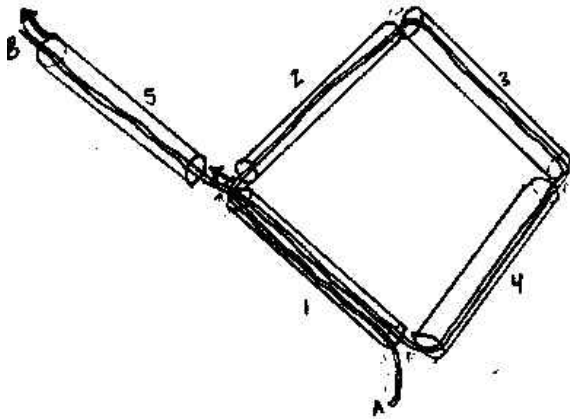

STEP 4.

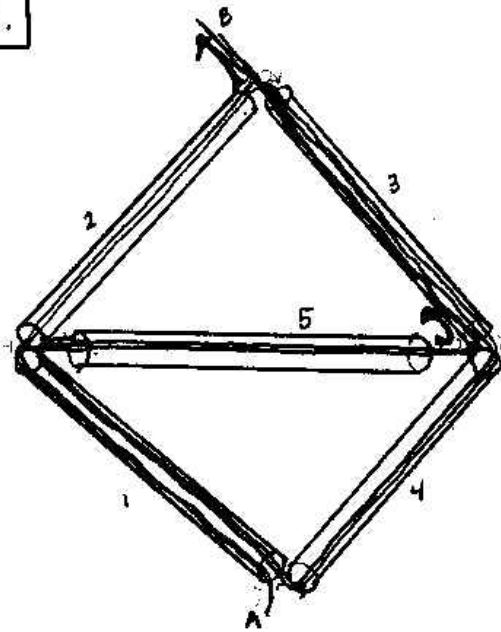

STEP 5.

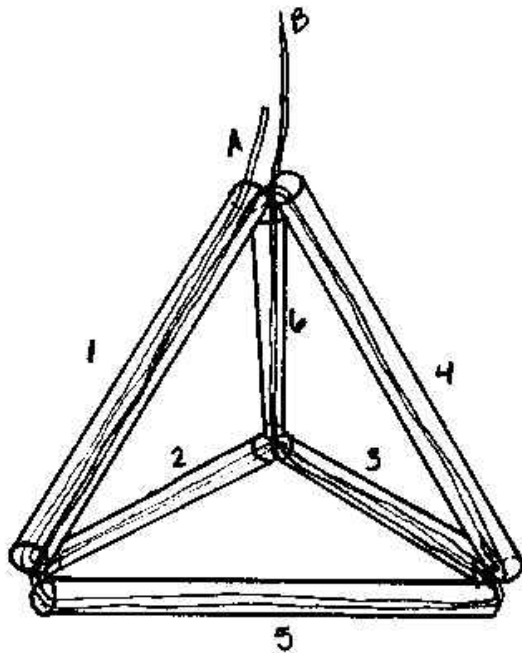
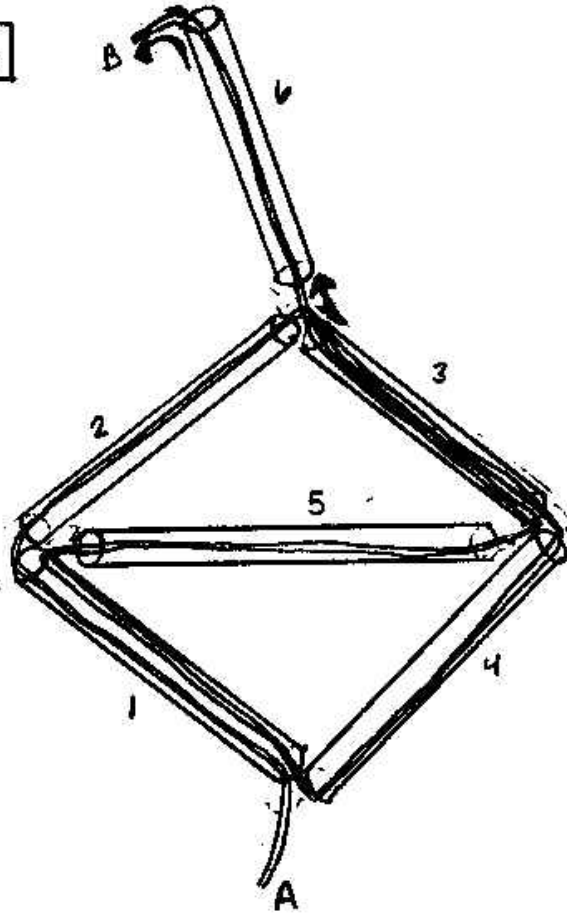

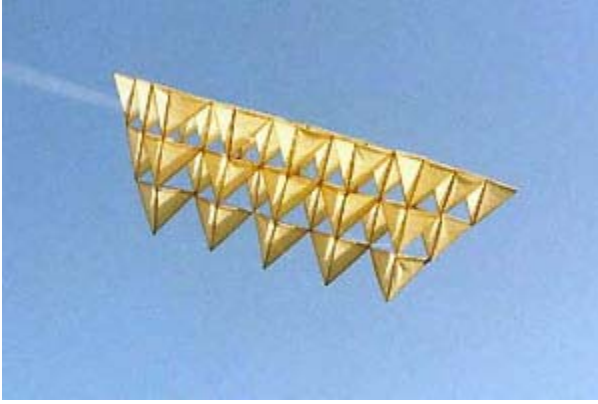

figure 1

<http://www.geocities.com/duyvis2001/gallery2.html>

Activity Evaluation Form

www.k12engineering.org**Activity Name:** _____**Grade Level the Activity was implemented at:** _____**Was this Activity effective at this grade level (if so, why, and if not, why not)?**

What were the Activity's strong points?

What were its weak points?

Was the suggested Time Required sufficient (if not, which aspects of the Activity took shorter or longer than expected)?**Was the supposed Cost accurate** (if not, what were some factors that contributed to either lower or higher costs)?**Do you think that the Activity sufficiently represented the listed MA Framework Standards** (if not, do you have suggestions that might improve the Activity's relevance)?**Was the suggested Preparation sufficient in raising the students' initial familiarity with the Activity's topic** (if not, do you have suggestions of steps that might be added here)?**If there were any attached Rubrics or Worksheets, were they effective** (if not, do you have suggestions for their improvement)?

Please return to: CEEO
105 Anderson Hall
Tufts University
Medford, MA 02155